

C2Sim: Complex Coalition Interoperation (Multiple Nations, Multiple Domains)

Mr. Adam Brook
QinetiQ
Cody Technology Park
Ively Road
Farnborough
Hampshire, GU14 0LX
UNITED KINGDOM
RABrook@qinetiq.com

ABSTRACT

This paper is one of a coordinated set prepared for a NATO Modelling and Simulation Group Lecture Series in Command and Control – Simulation Interoperability (C2Sim). This paper provides insights into the development of C2SIM interoperability solutions that have been developed within the context of complex coalition interoperation (multiple nations, multiple domains). It also covers some examples where C-BML has been used in the design and implementation of autonomous or robotic vehicle systems.

1.0 INTRODUCTION

This paper provides insights into the development of C2Sim interoperability solutions within the context of complex coalition interoperation (multiple nations, multiple domains). A number of examples have been implemented and these are discussed further in this paper.

The specific areas covered within this section include the following:

- NATO MSG Experimentation;
- SAFIR;
- CAGE IIIb; and
- French-German Training.

A further section discusses the various cases where Coalition Battle Management Language (C-BML) has been used to control simulated or real robotic systems. The systems discussed here are only described in outline and for fuller and more detailed information the reader is recommended to pursue the given references.

2.0 DEFINITION OF C2SIM IN COMPLEX ENVIRONMENTS

For the purposes of this paper a complex environment will have:

- More than one nation participating;
- Single or multiple domains;
- Multiple service branches;
- Multiple systems, networks and processes; and
- Distributed environments (multi-site operation).

This distinguishes it from a simple, single nation or single domain system¹.

3.0 USING C2SIM IN COMPLEX ENVIRONMENTS

3.1 Introduction

This section covers the four chosen examples where C2Sim systems have been used in complex environments.

3.2 NATO MSG Experimentation

The NATO Modelling and Simulation Groups MSG-048 (2006-10) and MSG-085 (2011-14) have worked on the development of C2Sim interoperability through the development of operational and technical use cases and requirements supported by practical experimentation using the products of the SISO C-BML and MSDL Product Development Groups.

3.2.1 MSG-048 Final Experimentation 2009

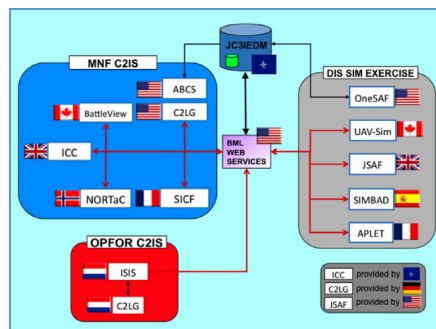

Figure 1: Systems in MSG-048 Final Experimentation.

MSG-048 conducted significant experiments throughout its existence and these culminated in a final experiment. Figure 1 shows the systems used in the group's final experiment which was held at George Mason University in Manassas in 2009. Two C2 cells generated orders for friendly blue forces and enemy red forces (played by the Netherlands). Preliminary Course of Action (COA) Analysis support was provided by the French Aide à la PPlanification d'Engagement Tactique terrestre (APLET) tool. A number of simulations on a Distributed Interactive Simulation (DIS) network provided the real-time simulation capability. All the systems were co-located and this was very beneficial since at this relatively early stage there were still a number of technical problems to overcome. The following points were noted:

- Information exchange worked well – for both orders and reports;
- Excel-based Battlebooks are insufficient for complex, multi-national C2-Sim federations;
- The whims of Exercise Controller need to be addressed; and
- Consistent initialisation data and processes are required.

The group's final report [1] gives an in-depth account of the group's work and achievements.

¹ Please note that this definition is not applied in the orthodox and rigorous sense, merely to help develop the understanding of the subject in these papers.

3.2.2 MSG-085 Experimentation

MSG-085 was a follow-on Technical Activity to MSG-048 which is focused on assessment and requirements for both C-BML and MSDL, advancing towards an operational employment. The final report of MSG-085 [2] gives a full account of the achievements and work undertaken by this group.

The group had a number of concurrent activities to supporting the experimentation. An operational sub-group and a technical sub-group provided the bedrock for the activities. There then formed specialist groups cutting across the two sub-groups. These were the Common Interest Groups or CIGs which focussed on:

- Technical Infrastructure;
- Land Operations;
- Maritime Operations;
- Joint Mission Planning;
- Air and Autonomous Air Operations; and
- Requirements, Recommendations and Specifications.

The experimentation programme progressed over a number of iterations culminating in a distributed experiment and demonstration held at the US Army Mission Command Battle Lab at Fort Leavenworth in November 2013. This demonstration consisted of a number of vignettes showing a number of the group's work areas:

- Mission Planning using faster-than-real-time course of action analysis tools at multiple echelons according to the precepts of the NATO COPD;
- Joint and coalition C2 and simulation;
- Mission training in real time using the selected course of action; and
- Technical work areas including:
 - Use of multiple C-BML servers;
 - Translation between C-BML schemas;
 - Multi-purpose server systems;
 - Use of MSDL for unified initialization; and
 - High and low performance networks.

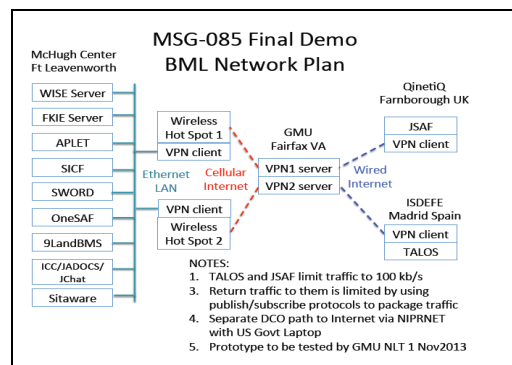

Figure 2: MSG-085 Final Demonstration Network Plan.

Figure 2 shows the final network plan used by MSG-085 for its main experiment centred at Fort Leavenworth and distributed across four sites in the USA and Europe.

3.2.3 MSG-085 Technical Lessons Identified

- Integration of C2-Sim into Commercial Off The Shelf (COTS) system, 9LandBMS, showed the potential capability of a C2-Sim-enabled planning tool;
- The chosen vignettes showed how C2-Sim-enabled tools could be used to support the development of complex, multi-echelon, multi-discipline military orders in a COPD process;
- Geographic distribution of systems is not a technical challenge using VPN tunnelling or dedicated networks;
- C-BML works well on low bandwidth connections; and
- C-BML translation and forwarding services worked well.

3.3 SAFIR

3.3.1 Support to Anglo-French Interoperability and Readiness (SAFIR) Programme

A joint UK and French team demonstrated how simulation technologies can be used for military mission planning, distributed training and experimentation. This capability planned to contribute to the integration of UK and French forces and support the future Combined Joint Expeditionary Force (CJEF).

Exercise FLANDRES was a UK-FRA Interoperability Command Post Exercise (CPX) between FRA 3 Bde & UK 7 Bde conducted at Maillly-le-Camp in June 2011. The exercise was with real troops using their national C2 systems exchanging messages using Multinational Interoperability Programme (MIP) protocols. The C2 systems, the Bowman Combat Information Platform (BCIP) and the Système d'Information pour le Commandement des Forces (SICF), were stimulated by bespoke simulations and there was limited interchange of data between them. The MIP data exchange was at a low frequency and there was no direct means of supplying orders to the simulation systems from the C2 systems.

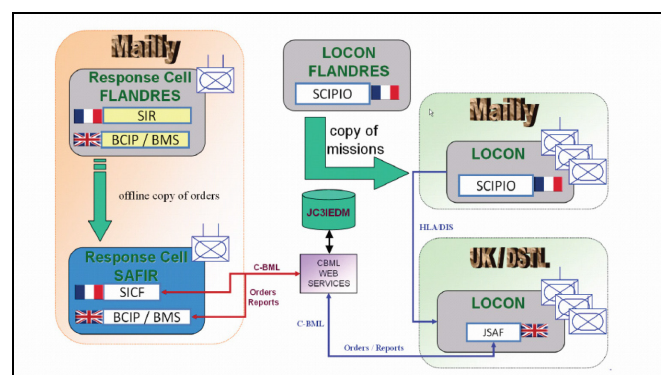

Figure 3: SAFIR Overview of Systems Deployed.

SAFIR was a capability concept demonstration system running concurrently with Ex FLANDRES which provided a Command & Control environment integrated with a distributed simulation environment controlled using Coalition Battle Management Language (C-BML). Figure 3 shows the main C2Sim systems deployed for SAFIR. An Anglo-French Government-Industry-Army team provided:

- Integrated C2: UK (BCIP 5.4) and French (SIR and SICF);
- Constructive simulation through JSAF and SCIPIO; and
- C-BML middleware applications.

Simulations were located at a number of sites across both France and the UK.

3.3.2 SAFIR Objectives

SAFIR had the following objectives:

- **Operational:** To conduct experimentation and support military training exercises through simulation to enhance UK/FRA force interoperability and readiness;
- **Experimentation:** To conduct visualisation and exploratory experiments to evaluate UK/FRA operational architectures and interoperability; and
- **Simulation:** To initiate a permanent simulation capability between UK and France to allow rapidly reconfigurable, distributed experimentation and training.

SAFIR was demonstrated to senior FRA & UK Army leaders and showed how:

- C-BML can be used to exchange operational information between C2 systems;
- Simulation can be used to support bi-lateral and coalition training events; and
- Distributed simulation can be used to enable cost-effective coalition training.

3.4 CAGE IIIb

3.4.1 TTCP CAGE IIIb 2015

The Technical Cooperation Programme (TTCP) [USA, CAN, GBR, AUS, NZ] Coalition Attack Guidance Experiment (CAGE) initiative is a series of distributed experiments/trials designed to investigate and evolve the TTCP nations' ability to conduct coalition Command and Control, focusing initially on Joint Fires, whilst also providing a research, development, analysis, test and evaluation environment (enabled by simulation).

The goals of CAGE are to:

- Identify the current barriers, and define improved techniques, to deliver effective coalition Network Centric Warfare (NCW);
- Provide recommendations for technologies, systems, tactics, and doctrine to improve coalition NCW effectiveness; and
- Extend and cross validate results by the appropriate experimental design and comparison of simulation and constructive modelling.

CAGE investigates not only technological interoperability, but also procedural (tactics, techniques, procedures/standard operating procedures) interoperability and enables coalition analysis. CAGE IIIb was conducted in a distributed environment with nodes in AUS(1), CAN(3) and UK(2). Each participant used national C2 equipment and M&S systems. In the case of the UK a C-BML-enabled ICC/JSAF system was used, the only site to do so.

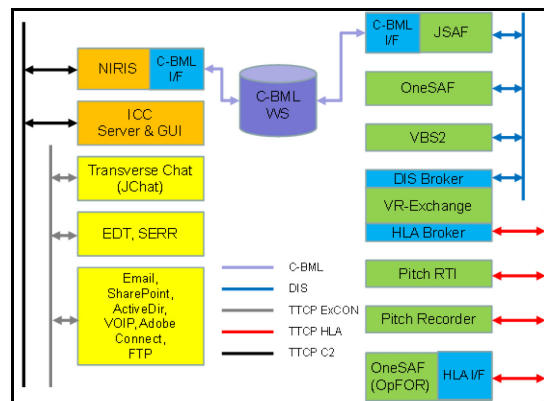

Figure 4: Architecture for UK CAGE IIIb Node.

Figure 4 shows the architecture for one of the UK nodes showing that as well as having a C2 network and DIS and HLA-e networks there were C2Sim and exercise control networks too. Often C2Sim still needs to work alongside other capabilities in the same environment. At the end of this event, one of the technical leaders in Canada wrote:

“My keen interest in this case is looking at trying to make C2-Sim, Sim-C2 and Sim-anything easier to implement at least here at CFWC”

3.4.2 TTCP CAGE IIIb – Lessons identified

- There is still a need to run C2Sim alongside conventional networked applications and services;
- There is a need for a readily-available, distributed, open, scalable and reusable capability to support experimentation across multiple initiatives;
- This environment would need to be pre-accredited (as far as possible) with a standard toolset including national C2 systems and simulations; and
- The Coalition Battle Management Language (C-BML) is a key enabler to integrate Live C2 systems with the underpinning synthetic environment.

TTCP has created a new initiative, the Virtual Interoperability Prototyping and Research Environment (VIPRE) to deliver this persistent, scalable environment.

Further information about the C2Sim aspects of CAGE IIIb has been published in [4].

3.5 French-German Training

3.5.1 FRA-DEU TRAINING

Under the French-German COMELEC technical cooperation programme a series of French-German army training initiatives have been conducted using C2Sim systems. These have used modified and extended national C2 and M&S systems.

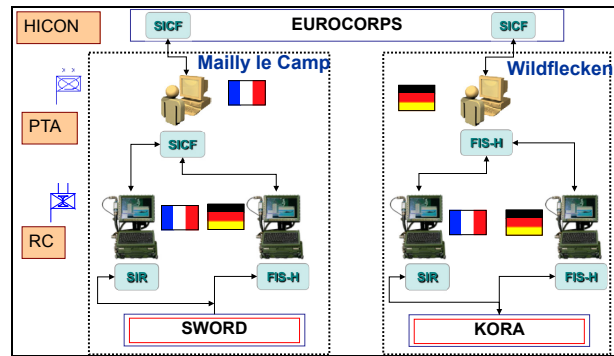

Figure 5: French-German C2Sim System Overall Architecture.

Figure 5 gives the overall system architecture for the French-German Training Network and shows the main C2 applications: SICF and SIR (FRA) and FIS-H (DEU) and the chosen national simulations, SWORD and KORA respectively. Each nation provided its own C2Sim server: Expertise et Logiciels pour les Liens d'Interopérabilité Permanents des Simulations et de leur Environnement (ELLIPSE) from France and the FKIE server from Germany.

3.5.2 Initialization Capabilities

The systems are initialised using shared MSDL files with:

- Force structure;
- APP6 symbols;
- Units Names; and
- Logistics (Fuel, ammunitions, resources, etc).

SISO MSDL does not support APP6 symbology or logistics so extensions were developed for these.

3.5.3 Execution Capabilities

C-BML was used for the exchange of:

- Orders;
- Reports (Blue Force Tracking, Situation Report, Reference Situations, Logistics, Enemy Reports); and
- Free Text Messages.

Free text messages are not part of the SISO Phase 1 C-BML standard and in the past there has been considerable debate about whether they should be included. The value of practical experiments is to help determine whether they are required and how to implement them in a useful manner.

3.5.4 FRA-DEU Lessons Identified

Lessons identified included:

- C2-Sim extensions need developing to cater for new specialisms, e.g. Logistics;
- MSDL provided consistent C2 and simulation initialisation;

- C-BML allowed automated C2-Simulation exchange of orders and reports;
- Successful validation of the new C-BML schema (IBML-2.2d);
- The C2 systems can become overwhelmed by reports from simulations. A solution could be the reduction of reports according to the following rules:
 - Only send reports after detection, or when a point or line in the terrain is reached);
 - Ensure that the simulation generates reports only when changes occurred; and
 - Simulations should comply with operational requirements (reports to be sent on time, under detection, or when a point or a line in the terrain is reached).
- Time synchronisation/time management:
 - For training/exercises it is desired to run the simulation faster than real-time or to jump back to earlier time stamps;
 - This is not always possible;
 - Time management solutions to investigate could be:
 - Use gateways to change DTG reports with wall clock time;
 - Use of fake NTP messages, these would still need to be able to reference a canonical time source.

Further information about the most recent developments of this capability has been described in [5].

4.0 THE USE OF C-BML TO CONTROL ROBOTIC FORCES

4.1 Introduction

C-BML has always been championed as suitable for the control of robotic systems. This section discusses a number of examples where this has been considered, developed and achieved. Figure 6 is a reminder of the concept of using C-BML to control robotic forces.

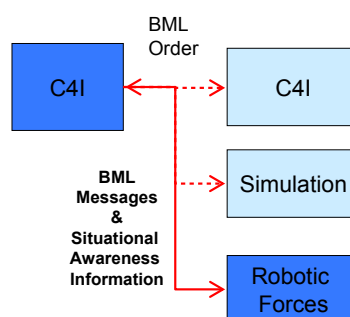

Figure 6: C-BML Used to Control Robotic Forces.

4.2 Concept for C2 to Autonomous Systems Test-bed (CAN)

This work investigated the potential to use C-BML to link operational C2 systems with a functional Unmanned Aerial Vehicle (UAV) control system.

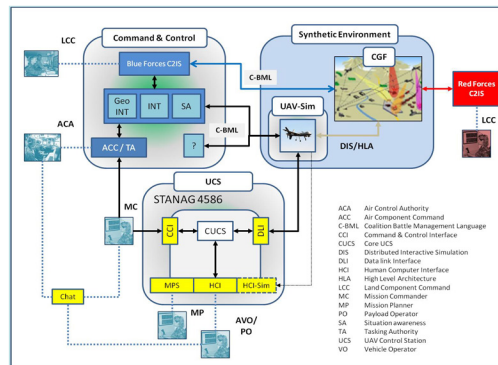

Figure 7: Architecture for Proposed Canadian UAV Test-bed.

Figure 7 shows three main architectural components: a C2 element; a UAV Control System (UCS), possibly controlling several UAVs and a synthetic environment including a simulated UAV and a Computer Generated Force (CGF). The ability to bridge the ‘swivel-chair’, air-gap interface between the C2 system and the UCS is a considerable attraction. So too is the fact that the UCS is represented by a real-world UCS rather than a surrogate and that it interacts with the UAV simulation using the same real world UAV message protocols, defined by NATO Stanag 4586.

One aspect of this work which has raised interest is the extent to which chat systems are used in the communication systems. Although chat messages are generally free-text, the chat system is as good a message handling system as any other and so it may be used to communicate C-BML: structured plans, orders, tasks, requests and reports and make them available to both chat users in human-readable form and as digital artefacts. This raises the concept of augmented chat, linking not only the human operators but the systems they are controlling and receiving information from.

In summary, the perceived benefits of the approach outlined here include:

- Elimination/reduction of air-gaps;
- Shorter decision making cycles with both commander and payload operator able to control UAV;
- Exploration of new C2ISR concepts; and
- Benefit from advances in UAV automation in order to achieve greater autonomy:
 - Operator (software agent) assisted control; and
 - Multiple Vehicle, single-operator control.

This work has been reported in, for example [3].

4.3 Naval USV Concept (TUR)

This example from the Turkish Naval Academy in Istanbul [6] is a design study which looks at a concept of using C-BML to model the deployment of multi-echelon patrol groups of naval Unmanned Surface Vessels (USVs). The concept uses a scenario containing a mixture of manned and autonomous vessels and these are both used to conduct patrol tasks and contribute to tactical and intelligence pictures through the sending of position reports and imagery and video. The USVs are able to navigate at sea and implement collision avoidance to set international standards. The mixture of manned and autonomous vessels; their message handling capabilities; level of autonomy and the assumptions and constraints to which they operate are all defined. Command of the USVs is through C-BML, expressing command from two different nations’ different C2 systems.

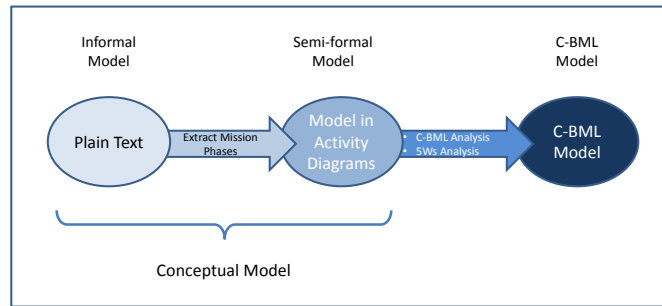

Figure 8: Developing C-BML for USV Concept.

Figure 8 shows the processes defined to develop a C-BML model for the command and control of the USV system. These have an analogue in the SISO Guidelines to Scenario Development (GSD) [7]. This particular study looks at a number of topics which have already been or could be considered by SISO for expanding the use cases which the C-BML standard should address. These include:

- Providing recurrent tasking;
- Representation of sequential and concurrent tasking;
- The use of Reports to model scenario events;
- Modelling of candidate target lists;
- Modelling of organisational structure;
- Modelling alternative actions and the associated decision selection processes; and
- Shortcomings in C-BML’s underlying JC3IEDM data model to express some of the system requirements.

The last point is very interesting since C-BML has traditionally been made to operate with simulations which themselves make the decisions through some sort of behavioural modelling process. Here it is proposed that C-BML itself should directly support logical decision making.

4.4 VMASC LVC Demonstration (USA)

The Virginia Modeling and Simulation Center (VMASC) demonstrated an early use of C-BML to control a model quad-copter in synthetic environment.

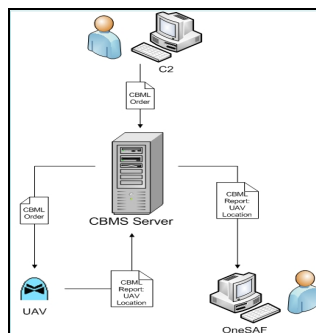

Figure 9: VMASC UAV Test Environment Architecture.

Figure 9 shows the basic architecture used. The C2 system was a relatively straight-forward application able to create and display C-BML orders and reports. The OneSAF CGF was used to provide a richer synthetic environment. The Coalition Battle Management Services (CBMS) server was able to receive connections via a secure network connection and the C2 controller could fly the quad-copter from a remote location. The underpinning CBMS system pioneered the use of Representational State Transfer (RESTful) services, i.e. the well-established and understood services and message protocols which have formed so much of the core capabilities used by the internet for many years.

The system starts with the C2 surrogate initialising OneSAF with a constructive UAV. A live UAV (quad-copter) then flies to an area under C-BML control and continuously reports its position through CBMS using C-BML. Position reports are reflected by the constructive UAV in OneSAF and the C2 surrogate shows a COP view.

4.5 C-BML with Autonomous Systems (UK)

Some initial work was conducted in the UK under the TTCP CAGE IIIa programme of 2014 to investigate the integration of an existing UK autonomous UAV control system with a C2 network using C-BML.

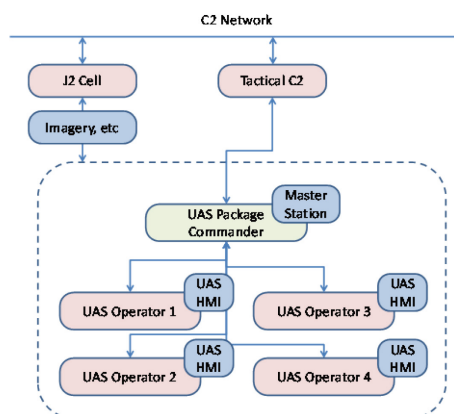

Figure 10: Autonomous UAV Control.

The architecture of the system is shown above in Figure 10. As with the Canadian concept covered earlier, the scope to integrate the UAS package commander's station with the C2 network providing direct exchange of digital information would be greatly enhanced by the use of C-BML, for example permitting the exchange of Air Tasking Orders (ATOs), Air Control Means (ACMs) and ACM Requests (ACMREQs). The work to develop this particular capability remains of interest in the UK.

4.6 UAV Simulation (UK)

A separate UK investigation into the use of C-BML with simulated UAVs has been to see how the C-BML Federation Object Models (FOMs) proposed by MSG-106 could be used in practice. To this end an ATO including a UAV missions was prepared using ICC and converted into C-BML. A modified UAV control station used that C-BML to task a number of simulated UAVs. These implemented the *low-level* C-BML FOM which concentrates on the interactions necessary to provide 'low-level tasking of individual elements' as opposed to the *high-level* FOM which can represent a C-BML order as given to a high-level unit. These FOMs fall into line with the High Level Architecture-Evolved (HLA-e) system [9] where the FOMs are modular, not monolithic, and composable. So, for example, the '5Ws' of a C-BML order would become parameters of a C-BML Order object and could be processed separately. In practice, it is probably simpler to communicate C-BML in data packages, e.g. wrapped in signal object. Equally, to date there has been little

interest in developing integral HLA-e capability in any operational C2 system. Figure 11 shows the Graphical user Interface (GUI) of the UK C-BML-enables UAV system.

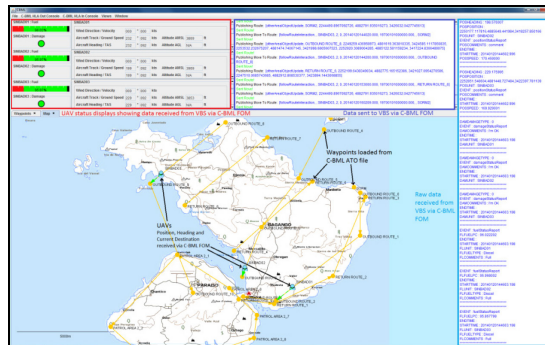

Figure 11: UAV Simulation Graphical User Interface.

In conjunction with this work, a degree of investigation has been undertaken to look at the Human-Machine Interface (HMI) aspects of the UAV control system GUI.

4.7 Control of Multiple Robotic Vehicles (DEU)

The FKIE Fraunhofer Institute in Germany has conducted pioneering work in the use of C-BML to control robotic systems [10]. They have proved the concept with both Unmanned Ground Vehicles (UGVs) and UAVs (again, quad-copters) and have developed language extensions to reflect their specific requirements. The UGVs are equipped with sensors to record imagery, video and various atmospheric and environmental measurements. The C-BML extensions cover:

- The operation of cameras and sensors, including the storage and access of imagery;
- Sensor measurement information;
- Unit self-description in the form of what its capabilities are.

The complete system also includes techniques for order and report aggregation and disaggregation to help simplify the operator’s workload. The robots are controlled using an adapted version of the Fraunhofer C2LG GUI to prepare the multi-robot orders and display their reports.

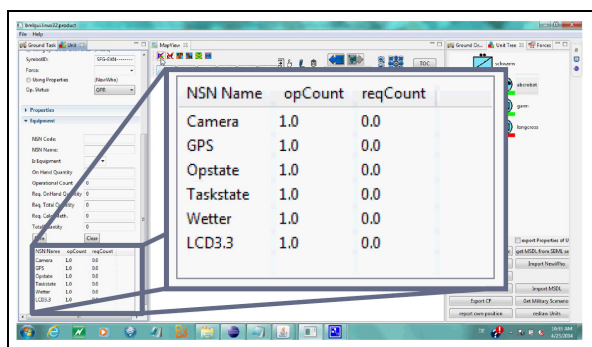

Figure 12: C2LG GUI Showing Reporting Detail from Fraunhofer Multi-Robot System.

Figure 12 shows a detail from the modified C2LG GUI used with the multi-robot system.

5.0 CONCLUSIONS

The various work described in this paper shows that MSDL and C-BML, the principal C2Sim standards may be used with great effect to develop complex joint and coalition C2Sim systems for use in a number of fields including Joint Mission Planning and Training. The work also shows that C2Sim standards are appropriate to use to enable autonomous or robotic forces to be integrated with operational C2 and simulation systems.

6.0 REFERENCES

- [1] NATO MSG-048 (C-BML) Final Report, 2010, NATO Technical Report , RTO-TR-MSG-048
- [2] Modelling & Simulation Group 085: Standardisation for C2-Simulation Interoperation, MSG-085 Final Report, 2014, NATO Technical Report, STO-TR-MSG-085
- [3] Hassaine, F, Heffner, K, Towards Intelligent Operator Interfaces in Support of Autonomous UVS Operations, 16th ICCRTS 2011
- [4] Brook, A, Mifsud, M, Using C-BML in a persistent Coalition C2-Simulation Experimentation Environment, 20th ICCRTS 2015
- [5] Khayari, R, Lotz, H, Krosta, U, Khimeche, L, Cuneo, X, Remmersmann, T, Practical Use of BML and MSDL Standards for Supporting French-German Training, SISO Paper 15F-SIW-014
- [6] Ünal, Ö, Topçu, O, Turkish Naval Academy, Istanbul, Modelling unmanned surface vehicle patrol missions with Coalition Battle Management Language, Journal of Defense Modelling and Simulation, 2014
- [7] SISO Guideline on scenario Development for Simulation Environments, Version 4.0 Draft, 20 Nov 2014
- [8] Diallo, S, An Introduction to Battle Management Services (CBMS), BML Symposium, 2011, GMU 2011
- [9] HLA-e Product Support Group, www.sisostds.org
- [10] Remmersmann, T, Schade, U, Rein, K, Tiderko, A, BML for Communicating with Multi-Robot Systems, 15F-SIW-001, Orlando, 2015

7.0 ABBREVIATIONS

Abbreviation	Expansion
ACM	Air Control Means
ACMREQ	Air Control Means Request
APLET	Aide à la PPlanification d'Engagement Tactique terrestre
ATO	Air Tasking Order
BCIP	Bowman Combat Information Platform
C2Sim	C2-Simulation

Abbreviation	Expansion
CAGE	Coalition Attack Guidance Experiment
C-BML	Coalition Battle Management Language
CGF	Computer Generated Force
CJEF	Combined Joint Expeditionary Force
COA	Course Of Action
COTS	Commercial Off The Shelf
CPX	Command Post Exercise
DGA	Direction Générale de l'Armement
DIS	Distributed Interactive Simulation
DSTL	Defence Science and Technology Laboratory
ELLIPSE	Expertise et Logiciels pour les Liens d'Interopérabilité Permanents des Simulations et de leur Environnement
GSD	[SISO] Guidelines to Scenario Development
GUI	Graphical User Interface
HMI	Human Machine Interface
MIP	Multinational Interoperability Programme
MSDL	Military Scenario Definition Language
RESTful	Representational State Transfer
SAFIR	Support to Anglo-French Interoperability Readiness
SICF	Système d'Information pour le Commandement des Forces
TTCP	The Technical Cooperation Programme
UAS	Unmanned Aerial System
UAV	Unmanned Aerial Vehicle
UCS	UAV Control System
UGV	Unmanned Ground Vehicle
USV	Unmanned Surface Vessels
VIPRE	Virtual Interoperability Prototyping and Research Environment
VMASC	Virginia Modeling and Simulation Center